

# Products for Hydrogen Applications

**Specialized products and professional services  
Meeting your needs in hydrogen applications**



Founded in 2010, WINGOIL is a leading global provider of instrumentation valves, fittings, and integrated systems. We operate factories in Germany, USA, and China, with inventory and sales service centers in Germany, USA, China, and UAE.

WINGOIL's main products include general instrumentation valves and fittings, medium and high pressure valves and fittings, high purity and ultra-high purity products, tubing, and sampling systems. The products are highly sought after and popular among customers in more than 100 countries and regions worldwide.

WINGOIL demonstrates its commitment to sustainable development and continuous improvement through various management system and product certifications, such as ISO 9001, ISO 14001, ISO 45001

## ■ Superiorities

### ■ EC79 and HGV 3.1 Compliance

Products are designed, manufactured, tested, and packaged to EC79 and HGV3.1 standards. A declaration of conformity or a third-party certification for EC79 or other relevant international standards can be provided.

### ■ Hydrogen-Compatible Materials

#### ★ Tailor-Made 316/316L Stainless Steel

Tailor-Made 316/316L stainless steel with nickel equivalent not less than 28.5% have excellent resistance to hydrogen embrittlement.

Material Grade	Composition %			Ni <sub>eq</sub> %
	Ni	Cr	Mo	
ASTM A479 316 SS	10-14	16-18	2-3	>22.4
WINGOIL Tailor-Made 316/316L SS	12-14	17-18	2.6-3	≥28.5

Hirayama's equation:  $Ni_{eq} = 12.6C + 0.35Si + 1.05Mn + Ni + 0.65Cr + 0.98Mo$

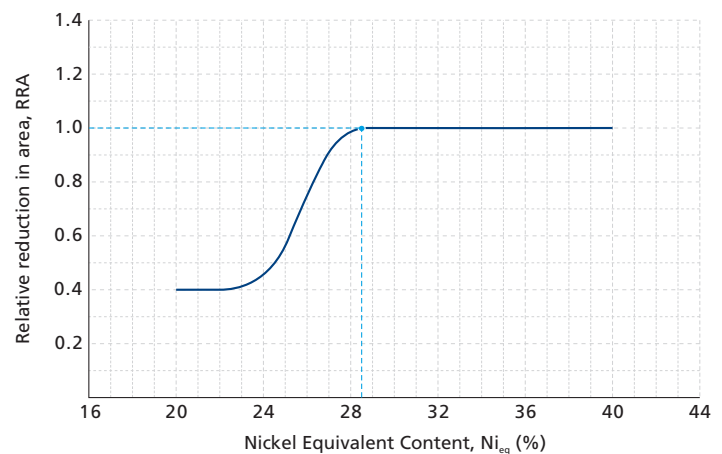

RRA is a quantitative description of hydrogen embrittlement risk

## ★ XM-19 Stainless Steel

XM-19 is a high strength austenitic stainless steel with excellent mechanical properties and resistance to hydrogen embrittlement. WINGOIL utilizes XM-19 for components requiring high mechanical strength, such as stems of medium pressure ball valves and lower stems of medium pressure needle valves.

## ★ Low-Temperature FKM and EPDM

FKM and EPDM O-rings conform to EC79 standard, offering excellent performance in terms of hydrogen compatibility and low temperature (-40 °C).

# Stringent Test and Leak Rate Standards

WINGOIL leak rate standards are significantly more stringent than those required by HGV 3.1 and EC79.

Products	Leak Rate Standard		
	WINGOIL	EC79	HGV 3.1
Valves and Other Products	$\leq 1 \times 10^{-6}$ Ncm <sup>3</sup> /s	$\leq 10$ Ncm <sup>3</sup> /h	$\leq 10$ Ncm <sup>3</sup> /h
	11.6 days/Ncm <sup>3</sup>	6 minutes/Ncm <sup>3</sup>	6 minutes/Ncm <sup>3</sup>
Tube Fittings	$\leq 1 \times 10^{-9}$ Ncm <sup>3</sup> /s	$\leq 10$ Ncm <sup>3</sup> /h	$\leq 10$ Ncm <sup>3</sup> /h
	32 years/Ncm <sup>3</sup>	6 minutes/Ncm <sup>3</sup>	6 minutes/Ncm <sup>3</sup>

Proportional sampling helium leak tests are conducted on valves, filters, quick-connects, and hoses. Each valve, filter, quick-connect, and hose is bubble tested using a helium-nitrogen gas mixture prior to shipment.

# Assembly by Torque

WINGOIL double ferrule fittings can be assembled by torque or by turns. Assembly-by-torque can significantly enhance efficiency and quality, making it perfect for mass production.



Assembly by Torque



Tool Kit

# Products

## Fittings

### ★ Tube Fittings

6D Series



- ◆ Allowable Working Pressure:  $\geq 6,500$  psig (450 bar)
- ◆ Working Temperature:  $-40 \sim 248$  °F ( $-40 \sim 120$  °C)
- ◆ Reassembly:  $\geq 25$  times
- ◆ Assembly by torque or by turns optional
- ◆ Match with TMP series instrumentation tubing or tubing that complies with ASTM A269 or A213

20D Series



- ◆ Max. Working Pressure: 20,000 psig (1379 bar)
- ◆ Working Temperature:  $-40 \sim 248$  °F ( $-40 \sim 120$  °C)
- ◆ Reassembly:  $\geq 25$  times
- ◆ Match with T20D and T20M series medium pressure tubing or equivalent
- ◆ Assembly by torque or by turns optional

20M Series



- ◆ Max. Working Pressure: 20,000 psig (1,379 bar)
- ◆ Working Temperature:  $-40 \sim 248$  °F ( $-40 \sim 120$  °C)
- ◆ Standard tapered threads
- ◆ Match with T20M series medium pressure tubing or equivalent

## ★ Pipe Fittings

PMH Series



- ◆ Max. Working Pressure: 15,000 psig (1,034 bar)
- ◆ Working Temperature: -40~248 °F (-40~120 °C)
- ◆ Compact size while maintaining the working pressure and flow capacity
- ◆ Rolled male thread provides higher strength and hardness

## ★ Adapter Fittings

AMH Series



- ◆ Max. Working Pressure: 20,000 psig (1,379 bar)
- ◆ Working Temperature: -40~248 °F (-40~120 °C)
- ◆ Compact size while maintaining the working pressure and flow capacity
- ◆ Rolled male thread provides higher strength and hardness

## Valves

### ★ Ball Valves

#### BU Series



- ◆ Max. Working Pressure: 6,500 psig (450 bar)
- ◆ Working Temperature: -40~248 °F (-40~120 °C)
- ◆ Spring-loaded seat offers a consistent and reliable sealing force
- ◆ PEEK seat offers exceptional wear resistance and excellent hydrogen compatibility

#### 20B Series

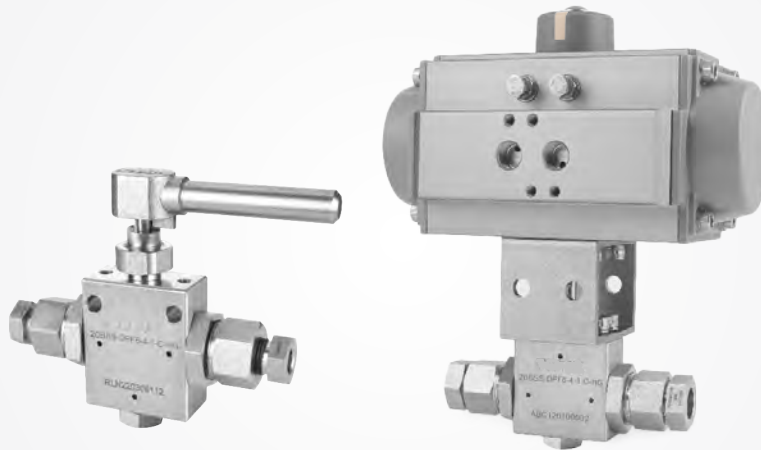

- ◆ Max. Working Pressure: 20,000 psig (1,379 bar)
- ◆ Working Temperature: -40~185 °F (-40~85 °C)
- ◆ Spring-loaded mechanism offers a consistent and reliable sealing force
- ◆ PI seat improves erosion resistance and withstands high temperatures
- ◆ Pneumatic actuator optional

## ★ Needle Valves

### NF Series



- ◆ Max. Working Pressure: 6,500 psig (450 bar)
- ◆ Working Temperature: -40~248 °F (-40~120 °C)
- ◆ One-piece forged valve body for higher integrity
- ◆ Two-piece stem design prevents abrasion between the stem tip and seat and reduces wear between the packing and stem
- ◆ Stem tip features a specially treated surface that ensures excellent sealing performance

### 20N Series



- ◆ Max. Working Pressure: 20,000 psig (1,379 bar)
- ◆ Working Temperature: -40~248 °F (-40~120 °C)
- ◆ Two-piece stem design prevents abrasion between the stem tip and seat and reduces wear between the packing and stem
- ◆ Stem tip features a specially treated surface that ensures excellent sealing performance

## ★ Check Valves

### CH Series



- ◆ Max. Working Pressure: 6,500 psig (450 bar)
- ◆ Working Temperature: -40~248 °F (-40~120 °C)
- ◆ Multiple cracking pressure ranges are optional, from 0~30 psig
- ◆ Mountable in any direction

**20CG Series**



- ◆ Max. Working Pressure: 20,000 psig (1,379 bar)
- ◆ Working Temperature: -40~248 °F (-40~120 °C)
- ◆ PEEK seat offers exceptional wear resistance and excellent hydrogen compatibility
- ◆ Metal cone to PEEK seating design ensures reliable performance under big pressure difference between upstream and downstream, suitable for hydrogen fueling applications
- ◆ Mountable in any direction

## ■ Regulators

### ★ Compact Piston Regulators

**RPCC Series**



- ◆ Max. Working Pressure: 6,000 psig (414 bar)
- ◆ Outlet Pressure Range: 0~1,800 psig (0~124 bar)
- ◆ Flow Coefficient (Cv): 0.06
- ◆ Piston sensing mechanism withstands high pressure spikes
- ◆ Compact and small size design
- ◆ Integrated 40 µm inlet filter for cleanliness and extended service life

### ★ General Piston Regulators

**RPGC Series**



- ◆ Max. Working Pressure: 6,000 psig (414 bar)
- ◆ Outlet Pressure Range: 0~2,500 psig (0~172 bar)
- ◆ Flow Coefficient (Cv): 0.06
- ◆ Piston sensing mechanism withstands high pressure spikes
- ◆ Built-in 40 µm inlet filter for cleanliness and extended service life
- ◆ A captured vent port on the bonnet for added safety

## ■ Hoses

### ★ Metal Hoses

MH, MM & MX Series

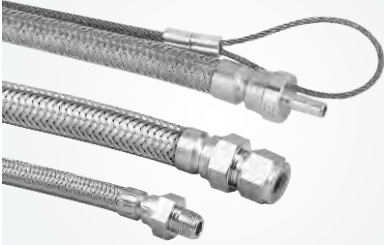

- ◆ Max. Working Pressure: 6,000 psig (414 bar)
- ◆ Working Temperature: -40~248 °F (-40~120 °C)
- ◆ Core tube made of 316L SS and overbraid made of 304 SS
- ◆ Welded fitting-to-hose construction provides a secure and reliable connection
- ◆ Excellent flexibility and small bend radius for easy operation in confined spaces

### ★ Medium and High Pressure Hoses

HHP Series



- ◆ Max. Working Pressure: 13,950 psig (962.5 bar)
- ◆ Working Temperature: -40~185 °F (-40~85 °C)
- ◆ Nominal Hose Sizes: DN6, DN16
- ◆ Fitting Material: Tailor-made 316/316L stainless steel with Ni<sub>eq</sub> ≥ 28.5%, providing excellent resistance to hydrogen embrittlement  
Core Tube Material: POM or PA, offering low permeability and excellent hydrogen compatibility
- ◆ Complies with ISO 19880-5 standards

## ■ Tubing

### TMP Series

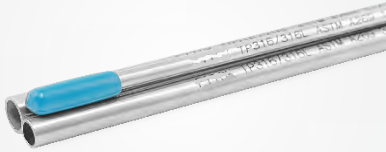

- ◆ Max. Working Pressure: 10,200 psig (710 bar)
- ◆ Working Temperature: -40~248 °F (-40~120 °C)
- ◆ Tube O.D.: 1/4"~1/2", 6 mm~12 mm
- ◆ Complies with ASTM A269 and ASTM A213 standards
- ◆ Standard lengths: 10 ft, 20 ft, 1 m, 2 m, 3 m and 6 m

### T20D Series

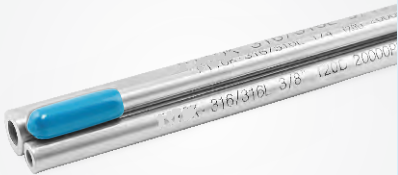

- ◆ Max. Working Pressure: 20,000 psig (1379 bar)
- ◆ Working Temperature: -40~248 °F (-40~120 °C)
- ◆ Tube O.D.: 1/4"~1"
- ◆ Dimensional tolerance complies with ASTM A269
- ◆ Best match with 20D series tube fittings
- ◆ Standard lengths: 10 ft, 20 ft, 1 m, 2 m, 3 m and 6 m

### T20M Series



- ◆ Max. Working Pressure: 20,000 psig (1379 bar)
- ◆ Working Temperature: -40~248 °F (-40~120 °C)
- ◆ Tube O.D.: 1/4"~1"
- ◆ Dimensional tolerance complies with ASME B1.1
- ◆ Best match with 20M series C&T fittings, and also compatible with 20D series tube fittings
- ◆ Standard lengths: 10 ft, 20 ft, 1 m, 2 m, 3 m and 6 m

## ■ Custom Services

Tube Bending

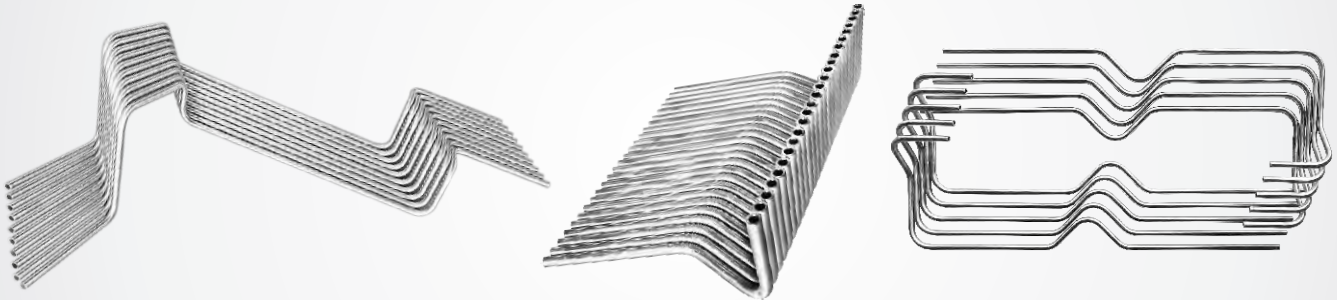

Custom-Length Straight Tubing with Well Treated Ends

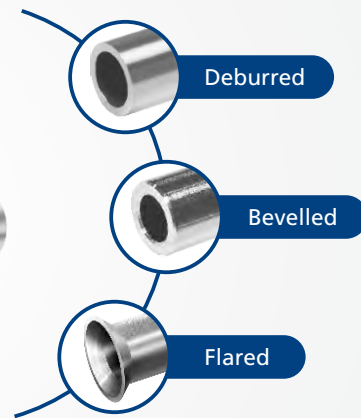

Cone and Thread Processing



Ferrule Presetting



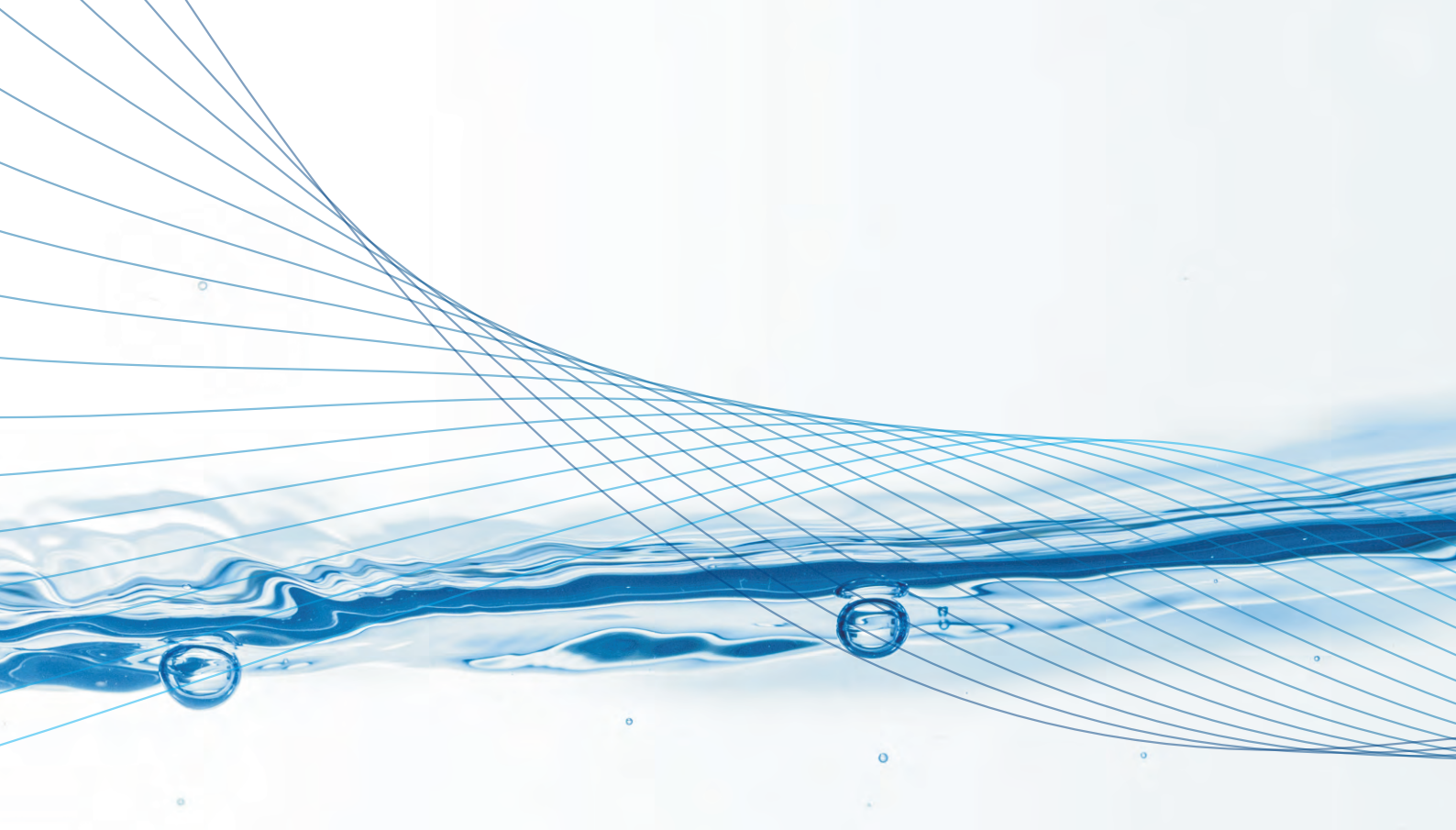

**NFS<sup>®</sup>**  
**FLUID TECHNOLOGY**